

Note:

D = 6 INCHES (for 3/4 & 1")
 4 INCHES (for 1 1/2" & 2")



CONCRETE BASE
 (4 INCHES X 4 INCHES X 4 INCHES)

H = STANDARD CLUSTER HEIGHT
 MAXIMUM OF 1.0 M

SERIES CONNECTION

- NOTES:
1. ALL SIZES AND LOCATIONS ARE SUBJECT TO CHANGE TO SUIT FIELD CONDITIONS
 2. THE DESIGNER SHALL NOT BE LIABLE FOR ANY ALTERATION/REVISION ON THE PLANS/DRAWINGS AND SPECIFICATIONS IMPROVED BY THE AUTHORIZED SUPERVISING ENGINEER DONE WITHOUT THEIR KNOWLEDGE THAT MAY IMPAIR THE STRENGTH OF THE PROJECT

CALAMBA WATER DISTRICT	
SHEET TITLE:	DATE
Series Connection Detail	11.15.2018
PROJECT TITLE:	LOCATION:
Installation of Service Connection	CALAMBA CITY
DRAWN BY:	SHEET NO.
AMM	1
CONTRACTOR:	ADDRESS:

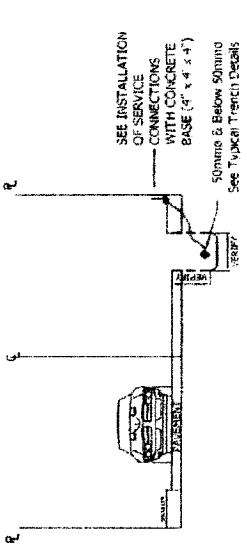

ROAD SECTION (Concrete Tapping Point)
SCALE NTS

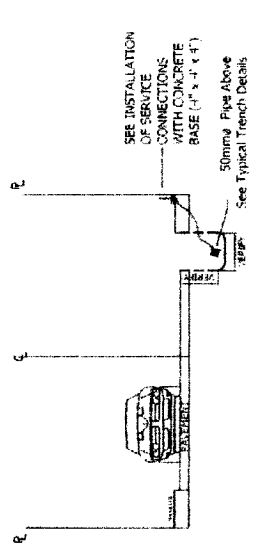

ROAD SECTION (Concrete Tapping Point)
SCALE NTS

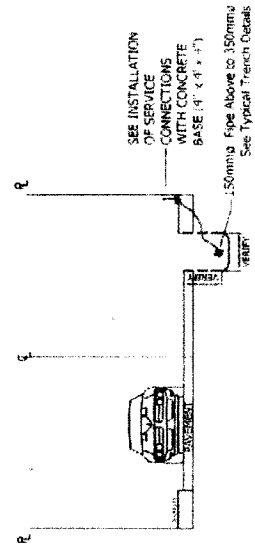

ROAD SECTION (Concrete Tapping Point)
SCALE NTS

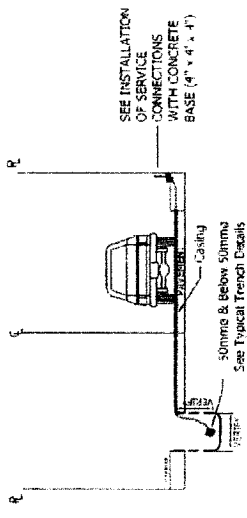

ROAD SECTION (Across Tapping Point)
SCALE NTS

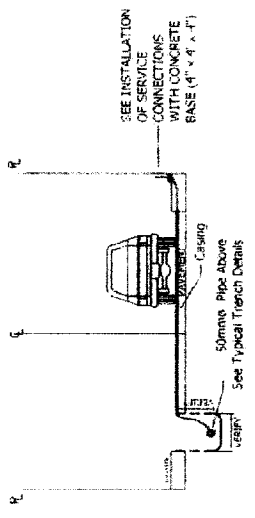

ROAD SECTION (Across Tapping Point)
SCALE NTS

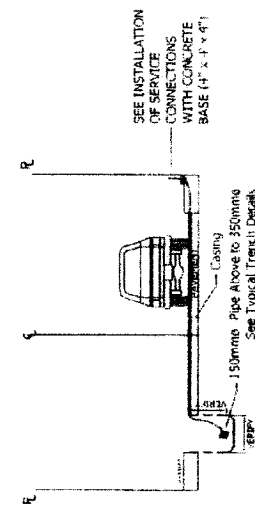

ROAD SECTION (Across Tapping Point)
SCALE NTS

- NOTES
1. ALL SIZES AND LOCATIONS ARE SUBJECT TO CHANGE TO SUIT FIELD CONDITIONS.
 2. THE DESIGNER SHALL NOT BE LIABLE FOR ANY ALTERATION/REVISION ON THE PLANS/DRAWINGS AND SPECIFICATIONS IMPROVED BY THE AUTHORIZED SUPERVISING ENGINEER DONE WITHOUT THEIR KNOWLEDGE THAT MAY IMPAIR THE STRENGTH OF THE PROJECT.

		CALAMBA WATER DISTRICT	
		SHEET TITLE: ROAD SECTION	DATE: 11.15.2018
DRAWN BY: AMM	PROJECT TITLE: SERVICE CONNECTION	LOCATION: CALAMBA CITY	SHEET NO: 1
CONTRACTOR:		ADDRESS:	

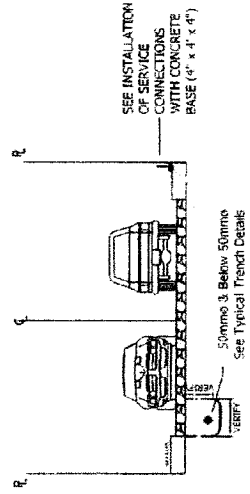

Across ordinary Tapping Point
SCALE
N/S

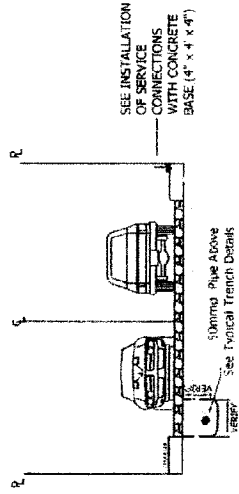

Across ordinary Tapping Point
SCALE
N/S

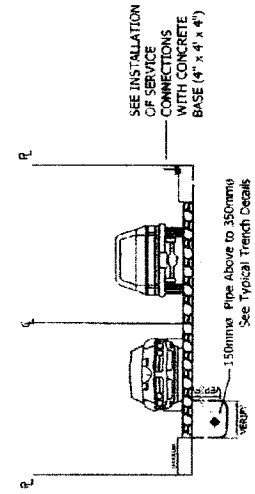

Across ordinary Tapping Point
SCALE
N/S

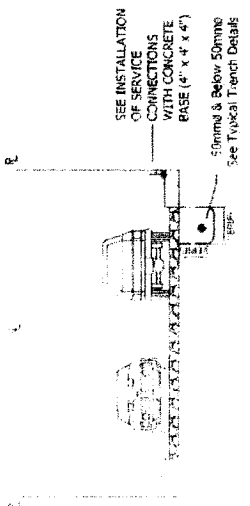

Ordinary Tapping Point
SCALE
N/S

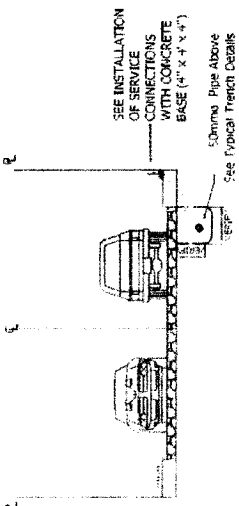

Ordinary Tapping Point
SCALE
N/S

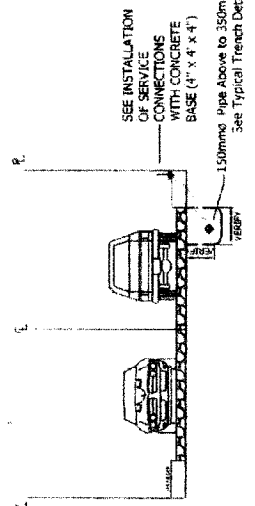

Ordinary Tapping Point
SCALE
N/S

		CALAMBA WATER DISTRICT	
		SHEET TITLE: Ordinary Tapping Detail	DATE: 11.15.2018
DRAWN BY: AMM	PROJECT TITLE: Installation of Service Connection	LOCATION: CALAMBA CITY	SHEET NO.: 2
CONTRACTOR:		ADDRESS:	

- NOTES:
- 1 ALL SIZES AND LOCATIONS ARE SUBJECT TO CHANGE TO SUIT FIELD CONDITIONS.
 - 2 THE DESIGNER SHALL NOT BE LIABLE FOR ANY ALTERATION/REVISION ON THE PLANS/DRAWINGS AND SPECIFICATIONS IMPROVED BY THE AUTHORIZED SUPERVISOR'S ENGINEER WITHOUT THEIR KNOWLEDGE THAT MAY IMPAIR THE STRENGTH OF THE PROJECT

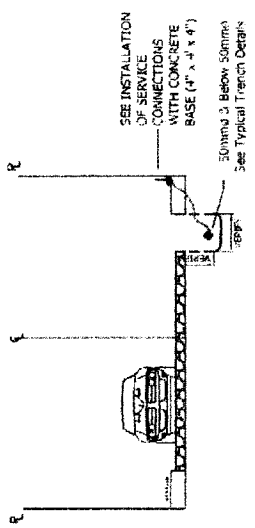

ROAD SECTION (Ordinary Tapping point)
SCALE NTS

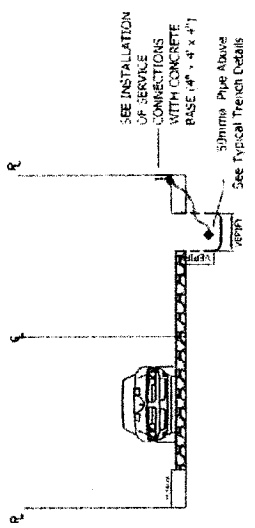

ROAD SECTION (Ordinary Tapping point)
SCALE NTS

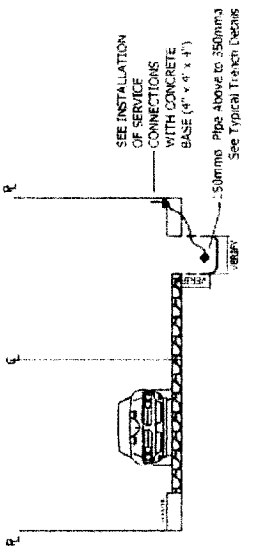

ROAD SECTION (Ordinary Tapping point)
SCALE NTS

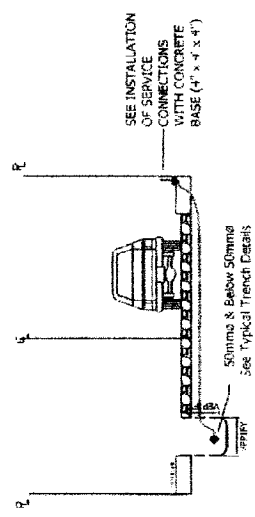

ROAD SECTION (Across ordinary Tapping Point)
SCALE NTS

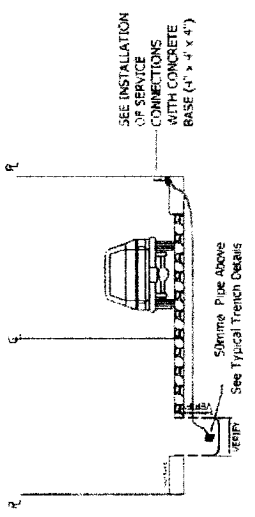

ROAD SECTION (Across ordinary Tapping Point)
SCALE NTS

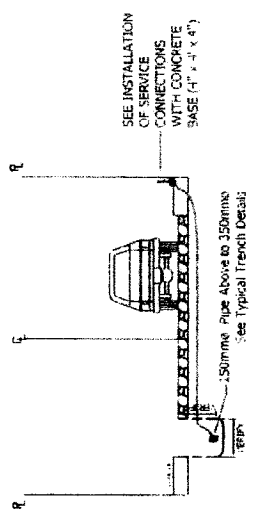

ROAD SECTION (Across ordinary Tapping Point)
SCALE NTS

- NOTES
- 1 ALL SIZES AND LOCATIONS ARE SUBJECT TO CHANGE TO SUIT FIELD CONDITIONS.
 - 2 THE DESIGNER SHALL NOT BE LIABLE FOR ANY ALTERATION/REVISION ON THE PLANS/DRAWINGS AND SPECIFICATIONS IMPROVED BY THE AUTHORIZED SUPERVISING ENGINEER DONE WITHOUT THEIR KNOWLEDGE THAT MAY IMPAIR THE STRENGTH OF THE PROJECT

	CALAMBA WATER DISTRICT	
	SHEET TITLE ROAD SECTION	DATE 11.15.2018
DRAWN BY AMM	PROJECT TITLE SERVICE CONNECTION	LOCATION CALAMBA CITY
CONTRACTOR AMM	ADDRESS AMM	SHEET NO. 2

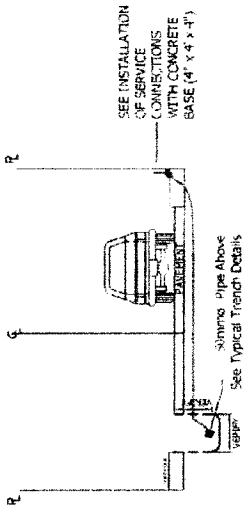

ROAD SECTION (Boring Tapping Point)
SCALE: 1/8" = 1'-0"

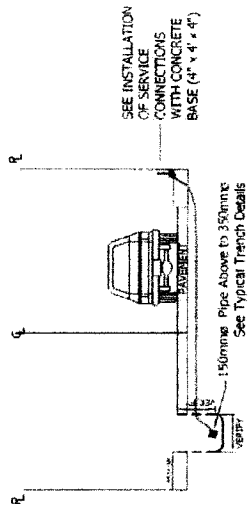

ROAD SECTION (Boring Tapping Point)
SCALE: 1/8" = 1'-0"

- NOTES
1. ALL SIZES AND LOCATIONS ARE SUBJECT TO CHANGE TO SUIT FIELD CONDITIONS.
 2. THE DESIGNER SHALL NOT BE LIABLE FOR ANY ALTERATION/REVISION ON THE PLANS/DRAWINGS AND SPECIFICATIONS IMPROVED BY THE AUTHORIZED SUPERVISING ENGINEER DONE WITHOUT THEIR KNOWLEDGE THAT MAY IMPAIR THE STRENGTH OF THE PROJECT.

		CALAMBA WATER DISTRICT	
SHEET TITLE: ROAD SECTION		DATE: 11.15.2018	
DRAWN BY: AMM		LOCATION: CALAMBA CITY	
PROJECT TITLE: SERVICE CONNECTION		SHEET NO.: 3	
CONTRACTOR:		ADDRESS:	

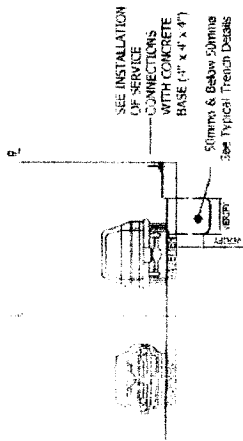

Concrete Tapping Point
SCALE 1/16"

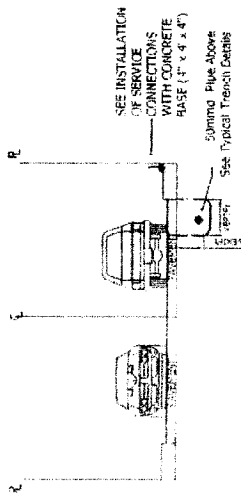

Concrete Tapping Point
SCALE 1/16"

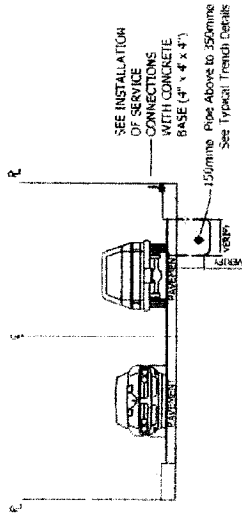

Concrete Tapping Point
SCALE 1/16"

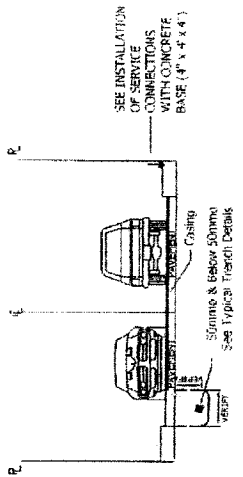

Across Concrete Tapping Point
SCALE 1/16"

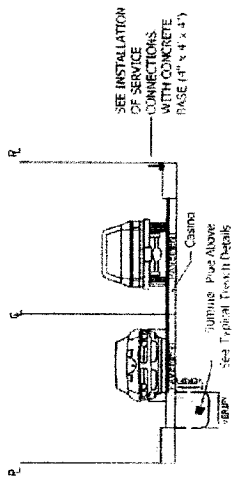

Across Concrete Tapping Point
SCALE 1/16"

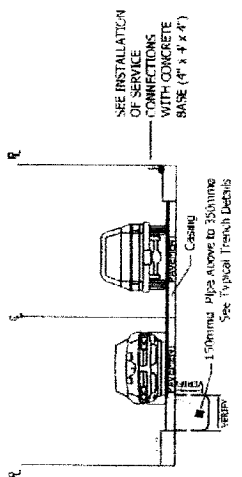

Across Concrete Tapping Point
SCALE 1/16"

- NOTES
- 1 ALL SIZES AND LOCATIONS ARE SUBJECT TO CHANGE TO SUIT FIELD CONDITIONS
 - 2 THE DESIGNER SHALL NOT BE LIABLE FOR ANY ALTERATION/REVISION ON THE PLANS/DRAWINGS AND SPECIFICATIONS IMPROVED BY THE AUTHORIZED SUPERVISING ENGINEER DONE WITHOUT THEIR KNOWLEDGE THAT MAY IMPAIR THE STRENGTH OF THE PROJECT.

	CALAMBA WATER DISTRICT	
	SHEET TITLE Concrete Tapping Detail	DATE 11.15.2018
DRAWN BY AMM	PROJECT TITLE Installation of Service Connection	LOCATION CALAMBA CITY
CONTRACTOR AMM	ADDRESS 	SHEET NO. 3

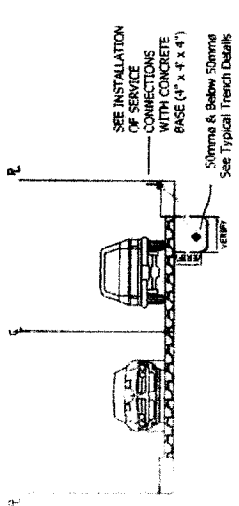

Hard Tapping point
SCALE
NTS

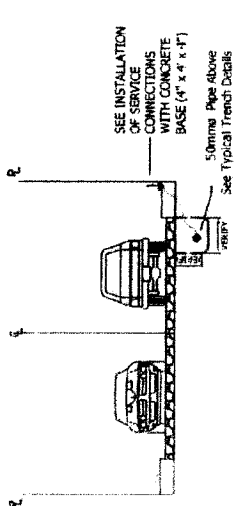

Hard Tapping point
SCALE
NTS

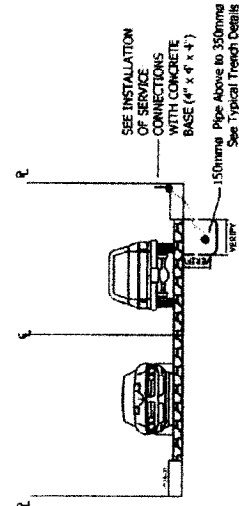

Hard Tapping point
SCALE
NTS

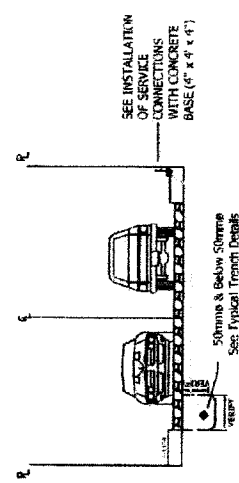

Across Hard Tapping Point
SCALE
NTS

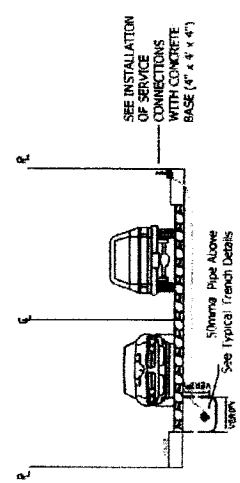

Across Hard Tapping Point
SCALE
NTS

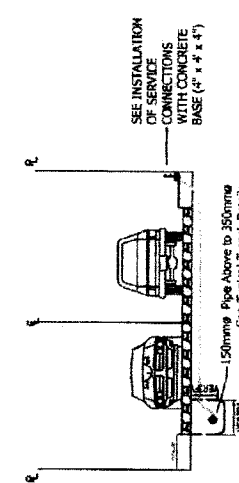

Across Hard Tapping Point
SCALE
NTS

	CALAMBA WATER DISTRICT	
	SHEET TITLE: Hard Tapping Detail	DATE: 11.15.2018
DRAWN BY: AMM	PROJECT TITLE: Installation of Service Connection	LOCATION: CALAMBA CITY
CONTRACTOR:	SHEET NO.: 4	ADDRESS:

- NOTES:
1. ALL SIZES AND LOCATIONS ARE SUBJECT TO CHANGE TO SUIT FIELD CONDITIONS.
 2. THE DESIGNER SHALL NOT BE LIABLE FOR ANY ALTERATION/PREVISION ON THE PLANS/DRAWINGS AND SPECIFICATIONS IMPROVED BY THE AUTHORIZED SUPERVISING ENGINEER DONE WITHOUT THEIR KNOWLEDGE THAT MAY IMPAIR THE STRENGTH OF THE PROJECT.

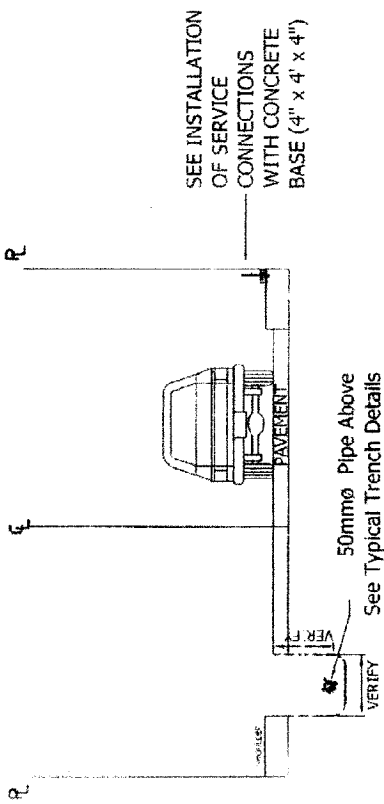

ROAD SECTION (Boring Tapping Point)

SCALE NTS

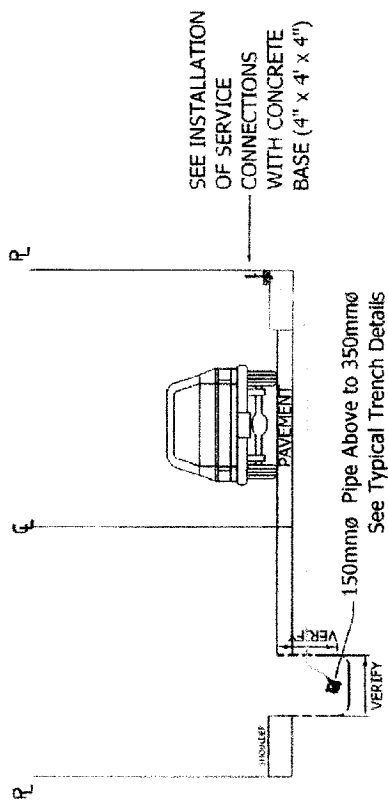

ROAD SECTION (Boring Tapping Point)

SCALE NTS

- NOTES:
- 1 ALL SIZES AND LOCATIONS ARE SUBJECT TO CHANGE TO SUIT FIELD CONDITIONS
 - 2 THE DESIGNER SHALL NOT BE LIABLE FOR ANY ALTERATION/REVISION ON THE PLANS/DRAWINGS AND SPECIFICATIONS IMPROVED BY THE AUTHORIZED SUPERVISING ENGINEER DONE WITHOUT THEIR KNOWLEDGE THAT MAY IMPAIR THE STRENGTH OF THE PROJECT.

	CALAMBA WATER DISTRICT	
	SHEET TITLE	DATE
	Boring Detail	11.15.2018
PROJECT TITLE	LOCATION	SHEET NO.
Installation of Service Connection	CALAMBA CITY	5
CONTRACTOR	ADDRESS	
AMM		

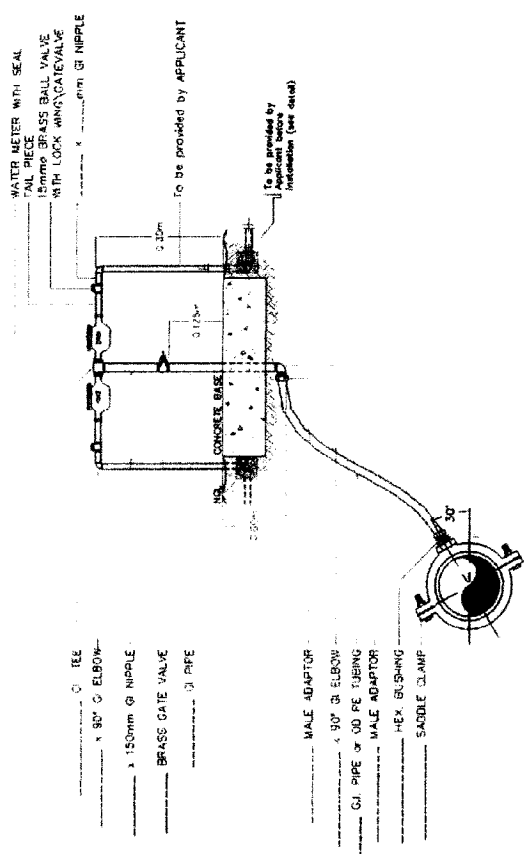

SERVICE CONNECTION

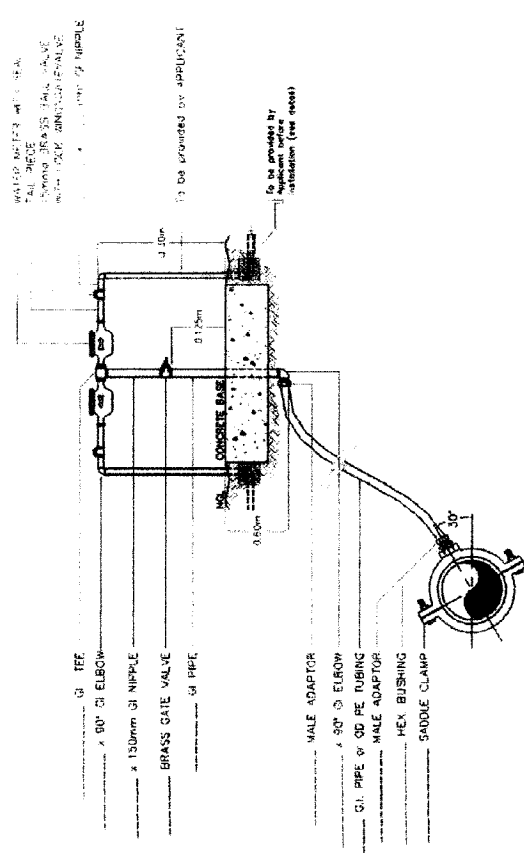

ACROSS SERVICE CONNECTION

CALAMBA WATER DISTRICT		SHEET TITLE:		DATE:	
ENGINEERING		INSTALLATION OF SERVICE CONNECTIONS		09/05/2006	
PLANNING AND DESIGN DIVISION		REVISION		SHEET NO.	
		NO.	DATE	INITIAL	APPROVED
					SD-5

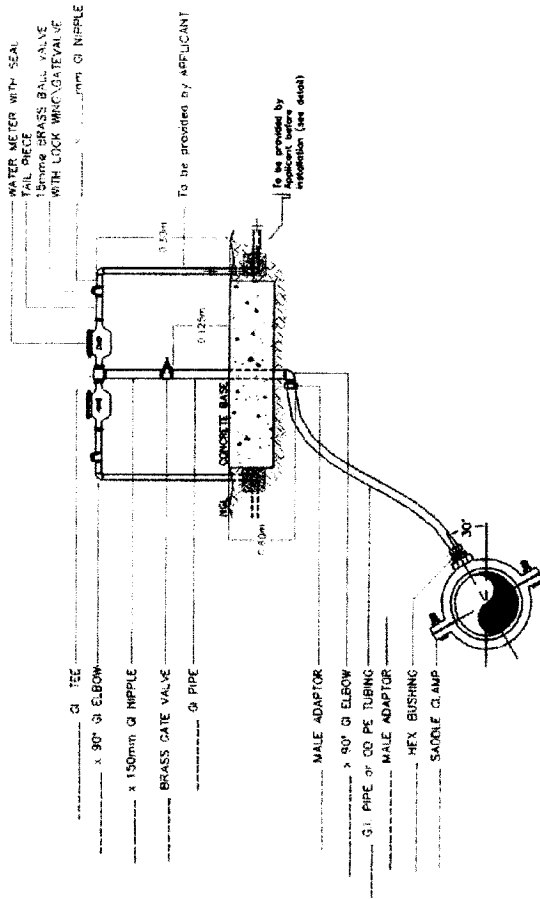

SERVICE CONNECTION

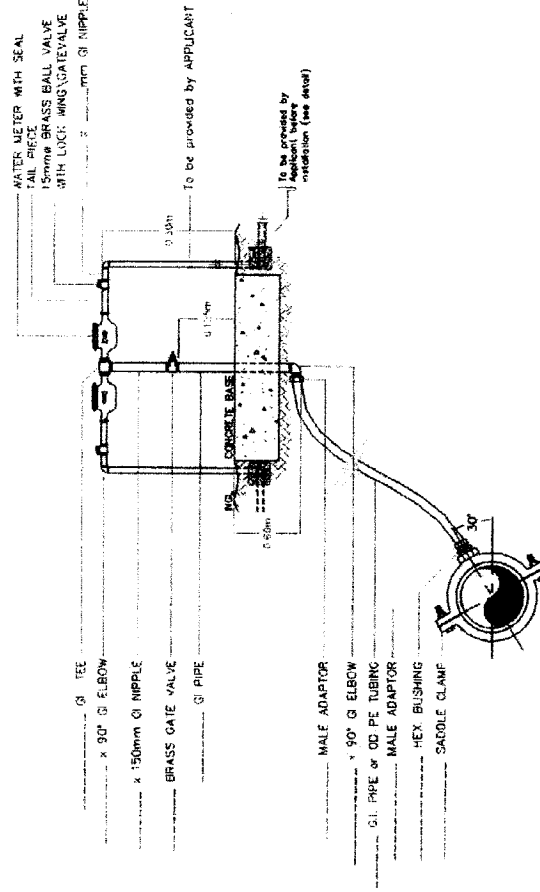

ACROSS SERVICE CONNECTION

CALAMBA WATER DISTRICT ENGINEERING PLANNING AND DESIGN DIVISION		SHEET TITLE: INSTALLATION OF SERVICE CONNECTIONS		REVISION		DATE: 09/05/2006	
				NO.		APPROVED	
				DATE		SHEET NO. SD-5	
				INITIAL			
				DESCRIPTION			

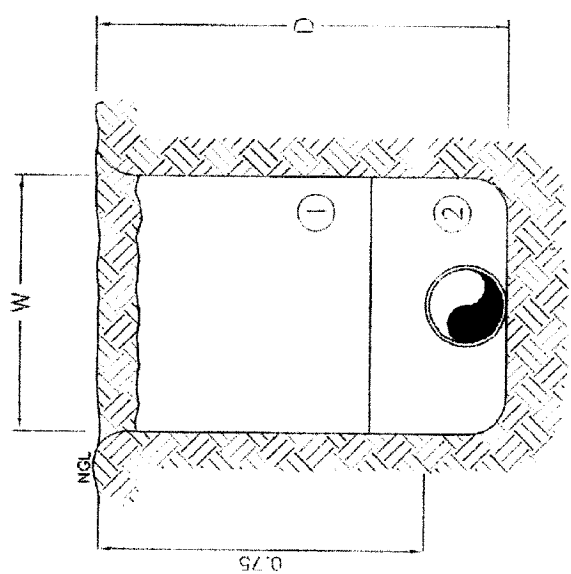

NORMAL INSTALLATION
WHERE SAND BEDDING
BACKFILL NOT REQUIRED

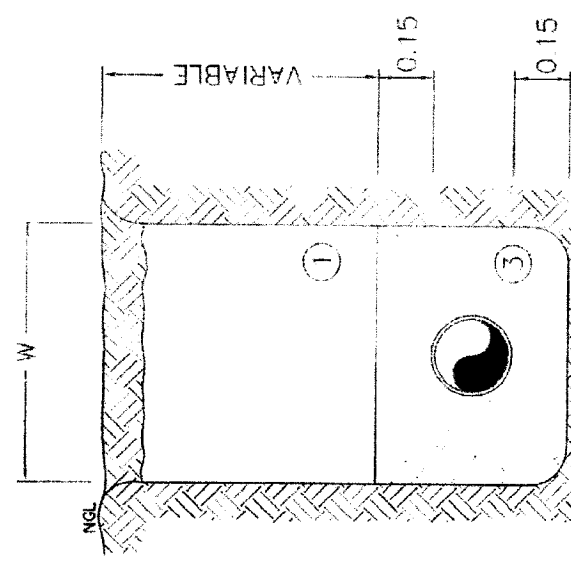

IN ROCK OR WHEN
ORDERED BY ENGINEER

TABLE OF TRENCH DIMENSIONS (IN METERS)

Pipe Diameter (mm)	Minimum Width (W)	Maximum Width (W)	Depth (D)
50mmø	0.20	0.30	0.50
75mmø	0.20	0.30	0.80
100mmø	0.40	0.70	0.85
150mmø	0.45	0.75	0.90
200mmø	0.50	0.80	0.95

LEGEND:

1. COMPACTED SELECTED NATIVE MATERIAL BACKFILL (SEE SPEC.)
2. COMPACTED SELECTED NATIVE MATERIAL IN 0.15 LAYERS (SEE SPEC.)
3. APPROVED SAND BEDDING & BACKFILL HAND PLACED AND COMPACTED.
4. PAYMENT FOR ANY RESURFACING WILL BE BASED ON MAXIMUM TRENCH WIDTHS PER SIZE PIPE SHOWN.

NOTE: ALL DIMENSIONS IN METERS EXCEPT WHERE OTHERWISE SHOWN.

CALAMBA WATER DISTRICT ENGINEERING PLANNING AND DESIGN DIVISION		SHEET TITLE: TYPICAL TRENCH DETAILS		DATE: 09/05/2006	
		NO. DATE INITIAL		REVISION DESCRIPTION APPROVED	
				SHEET NO. SD-1	